

NO.	NAME OF PARTS		MATERIAL	QTY	REMARKS	NO.	NAME OF PARTS		MATERIAL	QTY	REMARKS
1	VALVE BODY	ホントイ	SCS 13	1		4					
2	NOZZLE (A)	Aノズル	SUS 304	1	15~32mm	5					
			SCS 13	1	40, 50mm	6					
3	NOZZLE (B)	Bノズル	SUS 304	1	15~32mm	7					
			SCS 13	1	40, 50mm	8					

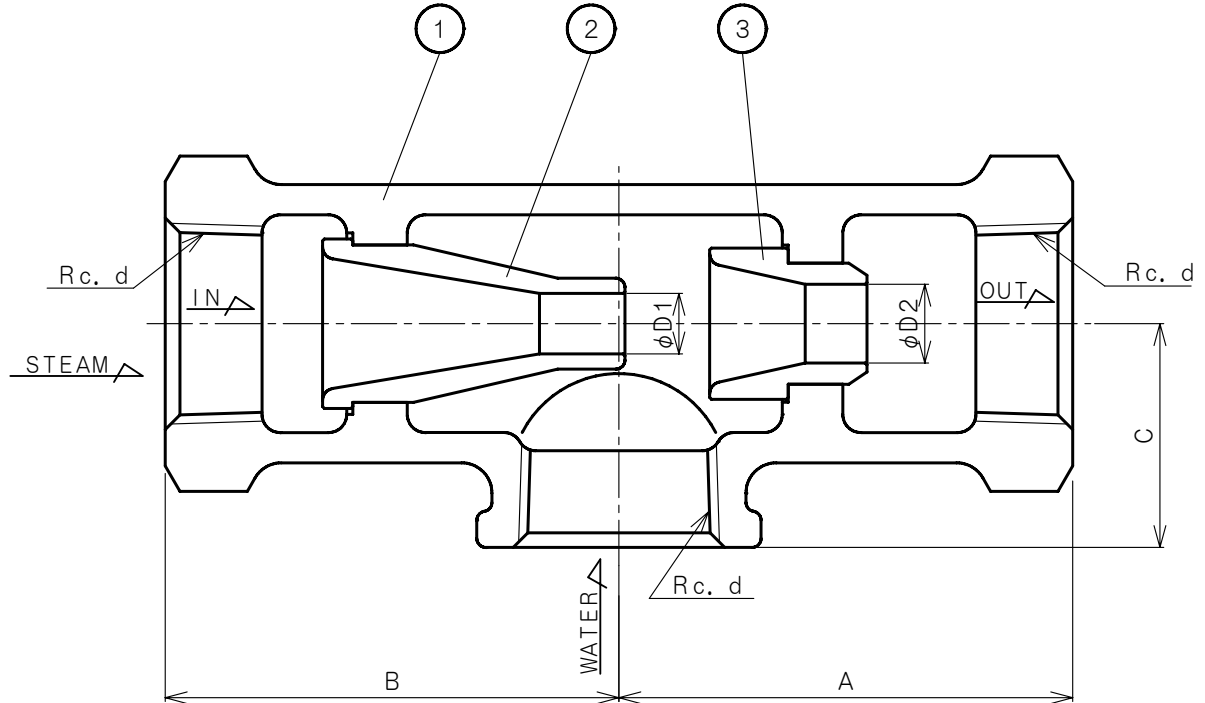

DIMENSIONS (mm)

SIZE	d	A	B	C	D1	D2
15	1/2	54	54	25	7	8
20	3/4	62	63	31	8	10
25	1	75	75	37	10	13
32	1 1/4	93	91	45	11	15
40	1 1/2	110	109	50	15	18
50	2	140	130	65	20	24

仕様

SPECIFICATIONS

適用流体 APPLICABLE FLUID	蒸気 STEAM
適用圧力 APPLICABLE PRESSURE	最高. MAX. 0.7MPa
発音限界温度 WARNING SOUND TEMPERATURE LIMIT	66℃

製品記号 CODE
QH1-D

QH-1 TYPE NOISELESS HEATER  QH-1 型 サイレンサ	APPROVED 承認	CHECK 検	DRAWING 製図
	K. Nakamura	S. Akiyama	K. Hamada
	DATE 日付	2022-7-25	
	NOTE	SCS 13	
APPROVED DWG. NO. 出図番号			
DWG. No. 原図番号			
QH1-11J-P			
SER. No. 管理番号			
	 <b>VENN CO., LTD.</b> 株式会社		