

水道法性能基準適合品
[鉛除去表面処理]

SIZE : 100

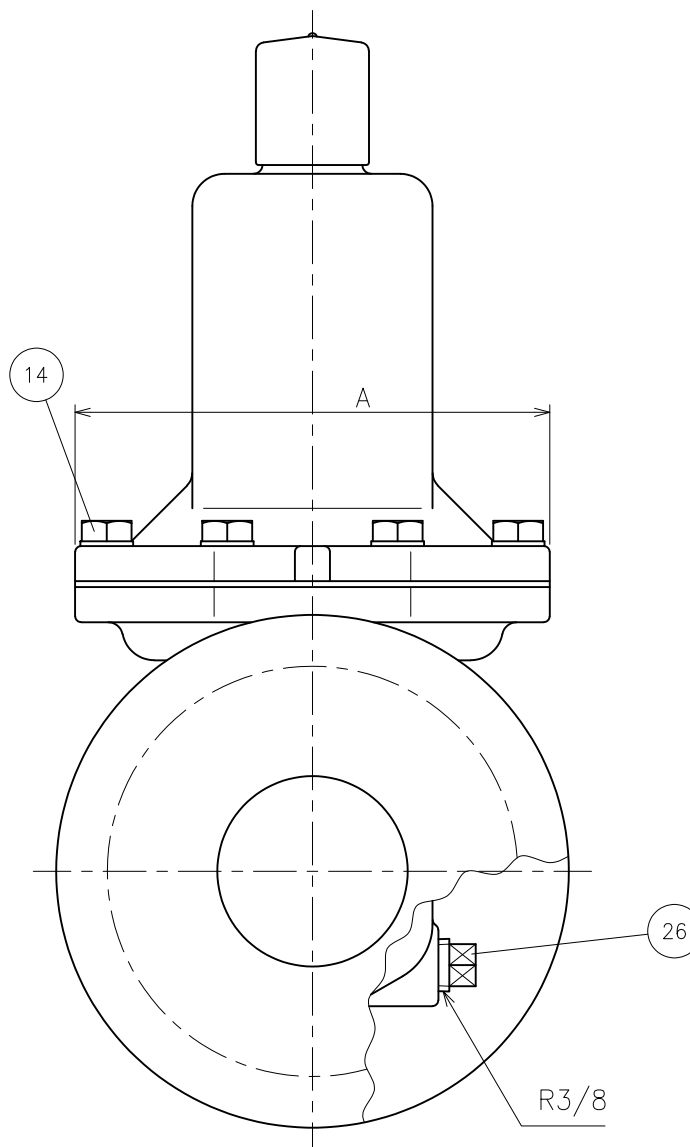
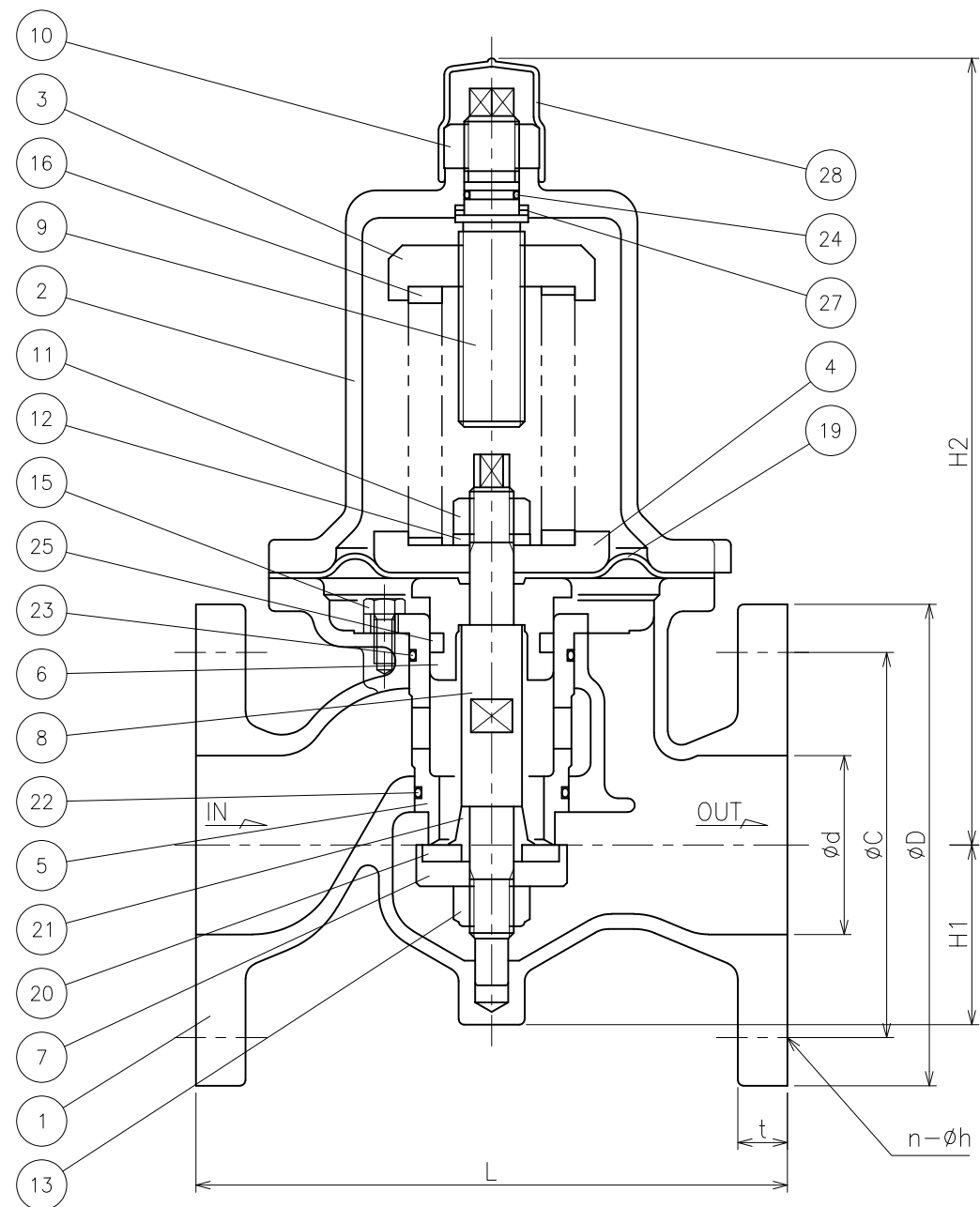

No.	NAME OF PARTS	部 品 名	MATERIAL	材 質
1	VALVE BODY	ホントイ	CAST BRONZE	CAC 406
2	SPRING CASE	バネケース	CAST IRON	FC 200
3	TOP SPRING SEAT	ウエバネウケ	"	"
4	BOTTOM SPRING SEAT	シタバネウケ	"	"
5	SEAT RING	ベンザ	CAST BRONZE	CAC 406
6	DIAPHRAGM SEAT	ダイヤフラムオサエ	"	"
7	DISC HOLDER	ディスクホルダー	STAINLESS STEEL	SUS 304
8	STEM	ステム	"	"
9	ADJUSTING SCREW	チョウセツネジ	"	SUS 416 or SUS 304
10	LOCK NUT	6カクナット	"	SUS 304
11	NUT	6カクナット	"	"
12	SPRING WASHER	バネザガネ	"	"
13	U NUT	U ナット	"	"
14	BOLT	6カクボルト	"	"
15	BOLT	6カクボルト	"	"
16	ADJUSTING SPRING	チョウセツバネ	SPRING STEEL	SWOSC
17	ADJUSTING SPRING	チョウセツバネ	"	SAE 9254 or SUP 9
18	ADJUSTING SPRING	チョウセツバネ	"	SAE 9254
19	DIAPHRAGM	ダイヤフラム	SYNTHETIC RUBBER	EPDM
20	SEAT DISC	シートディスク	"	"
21	DISC SEAT	ディスクオサエ	CAST BRONZE	CAC 406C
22	O RING	O リング	SYNTHETIC RUBBER	EPDM
23	O RING	O リング	"	"
24	O RING	O リング	"	"
25	O RING	O リング	"	"
26	PLUG	プラグ	BRASS	C 3604 B
27	WASHER	ザガネ	PTFE	PTFE
28	CAP	キャップ	"	PVC

DIMENSIONS (mm) FLANGE CODE : JIS 10K

SIZE	L	A	H1	H2	D	C	d	t	n	h
65	215	162	70	280	175	140	65	18	4	19
80	230	162	70	285	185	150	80	18	8	19
100	260	201	78	345	210	175	100	18	8	19

Q'TY SPRING TO BE USED IS FOUND ON THE FOLLOWING TABLE.

TYPE	ADJUSTING RANGE MPa	SIZE	PARTS No.	MATERIAL	Q'TY
RD-33FN TYPE L	0.05 ~ 0.35	65, 80	16	SWOSC	1
		100	17	SAE 9254	1
RD-33FN TYPE H	0.30 ~ 0.70	65, 80	16	SWOSC	1
		100	17 & 18	SAE 9254 & SUP 9	2

CODE 製品記号	ADJUSTING RANGE MPa
RD33FN-FL	0.05 ~ 0.35
RD33FN-FH	0.30 ~ 0.70

SPECIFICATIONS(仕様)	
FLUID(流体)	
INLET PRESS.(一次側圧力)	MPa
OUTLET PRESS.(二次側圧力)	MPa
TEMP.(温度)	℃

RD-33FN TYPE PRESSURE REDUCING VALVE RD-33FN 型 減圧弁	DRAWING 製 図	S. Sato
	CHECK 検 査	S. Hosokawa
	DATE 付 日	2024- 3-29
	NOTE	JWWA
APPROVED DWG.No. 出 図 番 号		
DWG.No.		
RD33FN-61E-P		