

SPECIFICATIONS (仕様)		
APPLICABLE TEMP. (適用温度)	MAX. 250℃	
APPLICABLE PRESS. (適用圧力)	MAX. 2.0 MPa	
EXPANSION & CONTRACTION (伸縮量)	+ 20mm - 50mm	
FLANGE CODE (フランジ規格)	JIS 20K ルーズフランジ	

NO.	NAME OF PARTS	MATERIAL	QTY	REMARKS	
1	PIPE PIECE	タンカン	2		
2	CENTER RING	STS 304	1	20~80A	
		STS 316L	1	100~150A	
3	BELLOWS	ベローズ	A 240-316L	1	
				2	100~150A
4	INTERNAL SLEEVE	ナイトウ	1		
5	EXTERNAL COVER	ガイトウ	2		
6	RING	リング	A 240-316L	2	20~80A
				4	100~150A
7	FLANGE	フランジ	SF 440A	2	
8	SET BOLT	セットボルト	STS 304	8	
9	ANCHOR BASE	アンカーベース	STS 304	1	
10	BOLT & NUT	ボルト & ナット	STS 304	2	

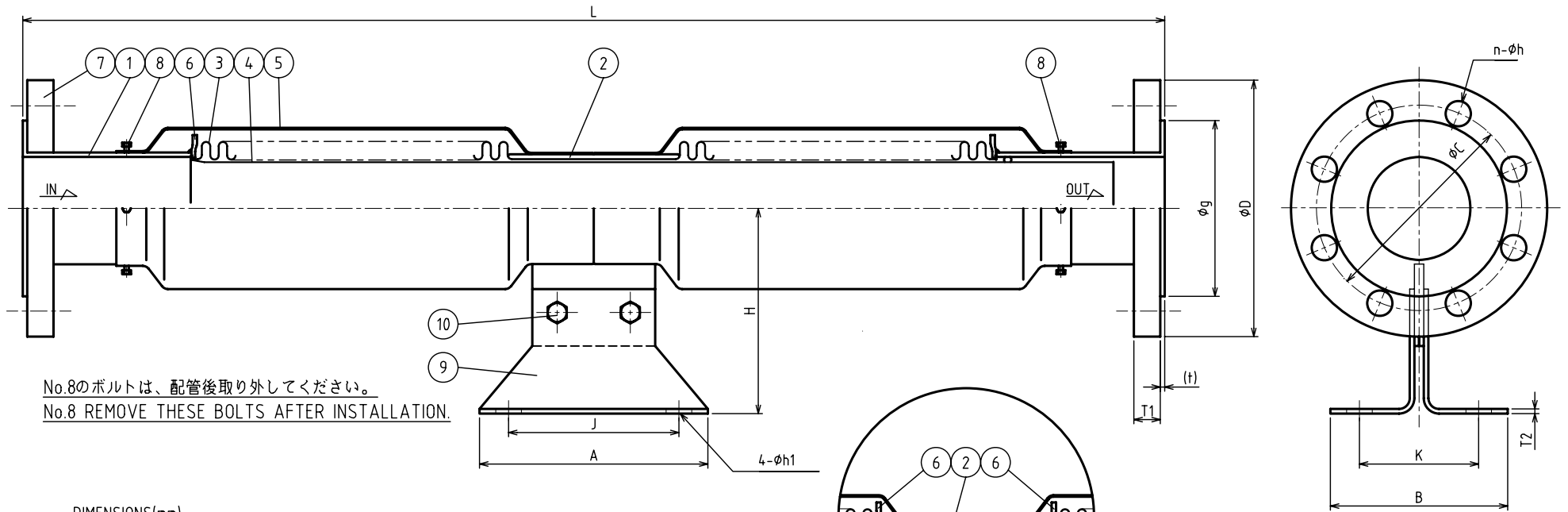

DIMENSIONS(mm)

SIZE	L	D	T1	(t)	g	C	n	h	H	ANCHOR BASE					
										J	K	h1	A	B	T2
20	680	100	15	1.8	56	75	4	15	100	100	60	12	130	100	3
25	680	125	15	1.8	67	90	4	19	100	100	60	12	130	100	3
32	680	135	16	1.8	76	100	4	19	120	100	70	12	130	100	3
40	680	140	16	1.8	81	105	4	19	120	100	70	12	130	110	3
50	680	155	16	1.8	96	120	8	19	130	100	80	15	130	110	3
65	780	175	18	1.8	116	140	8	19	140	120	100	15	160	150	3
80	780	200	20	2.0	132	160	8	23	150	120	110	15	160	150	3
100	880	225	22	2.0	160	185	8	23	170	120	130	19	160	190	4
125	880	270	24	2.0	195	225	8	25	200	120	150	19	160	190	4
150	930	305	26	2.0	230	260	12	25	220	160	180	23	220	230	4

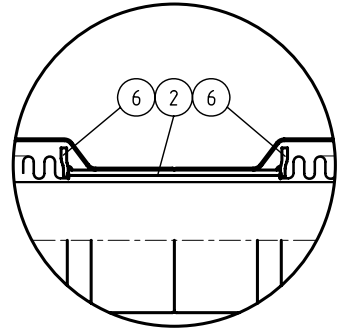

SIZE : 100~150

製品記号
CODE
JB24-N

JB-24 TYPE BELLOWS TYPE EXPANSION JOINT JB-24 型 ベローズ形 伸縮管継手	DRAWING 製 図	S. Akiyama
	CHECK 検 図	H. Kobayashi
	DATE 日 付	2023-5-10
	NOTE	
APPROVED DWG.No.	出 図 番 号	
DWG.No.		
JB24-01M-P		
VENN CO., LTD.		株式会社